

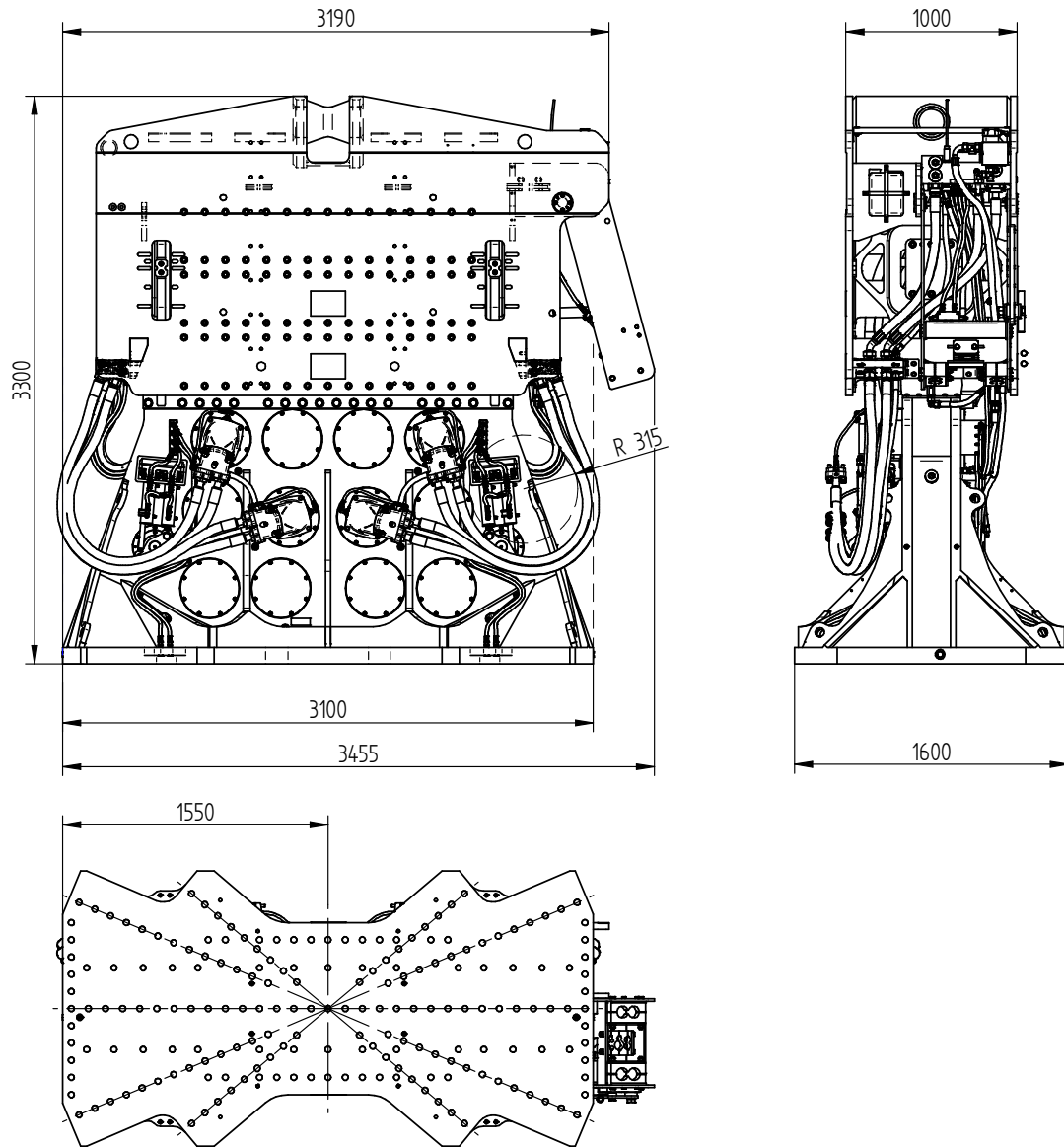

Specification sheet

PVE 90VM

Vibro Hammer



Specifications :

PVE 90VM

Eccentric moment	90 kgm	Clamps:	
Max. centrifugal force	4477 kN	Four sided clamps	PPK 150T
Max. frequency	2130 rpm	Transport weight per piece	1600 kg
Max. amplitude excl. 4xPPK 150T	13.3 mm	Double clamps	PPK 350T
Max. amplitude incl. 4xPPK 150T	9.1 mm	Transport weight per piece	3600 kg
Max. static line-pull	1500 kN		
Max. operating pressure	350 bar	Powerpack:	
Max. oil flow	2062 l/min	Model	1000P (2x)
Forced lubrication	yes		
Dynamic weight excl. 4xPPK 150T	13500 kg	Hose set:	
Dynamic weight incl. 4xPPK 150T	19900 kg	Length	60 m
Total weight excl. 4xPPK 150T and hoses	18500 kg	Transport weight (±)	2630 kg

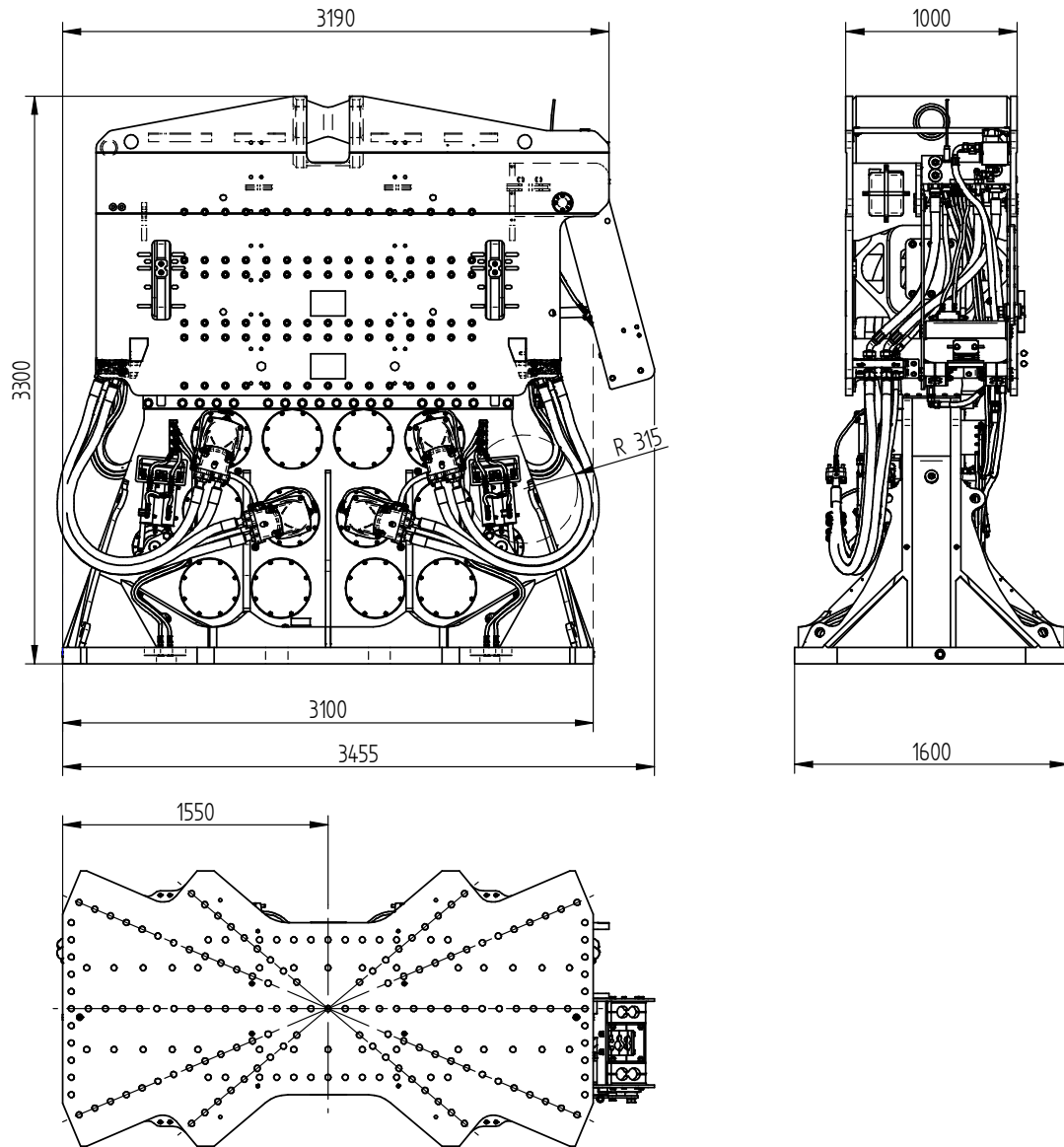

Technische Daten :

PVE 90VM

Statisches Moment	90 kgm	Klemmzange:	
Max. Fliehkraft	4477 kN	Universalzange	PPK 150T
Max. Drehzahl	2130 rpm	Transportgew. pro Stück	1600 kg
Max. Amplitude ohne 4xPPK 150T	13.3 mm	Rohrklemmzange	PPK 350T
Max. Amplitude mit 4xPPK 150T	9.1 mm	Transportgew. pro Stück	3600 kg
Max. Statische Zugkraft	1500 kN		
Max. Betriebsdruck	350 bar	Aggregat:	
Max. Fördermenge	2062 l/min	Modell	1000P (2x)
Zwangsschmierung	ja		
Dyn. Gewicht ohne 4xPPK 150T	13500 kg	Schlauchsatz:	
Dyn. Gewicht mit 4xPPK 150T	19900 kg	Länge	60 m
Gesamtgew. Ohne 4xPPK 150T & Schläuche	18500 kg	Transportgewicht (±)	2630 kg

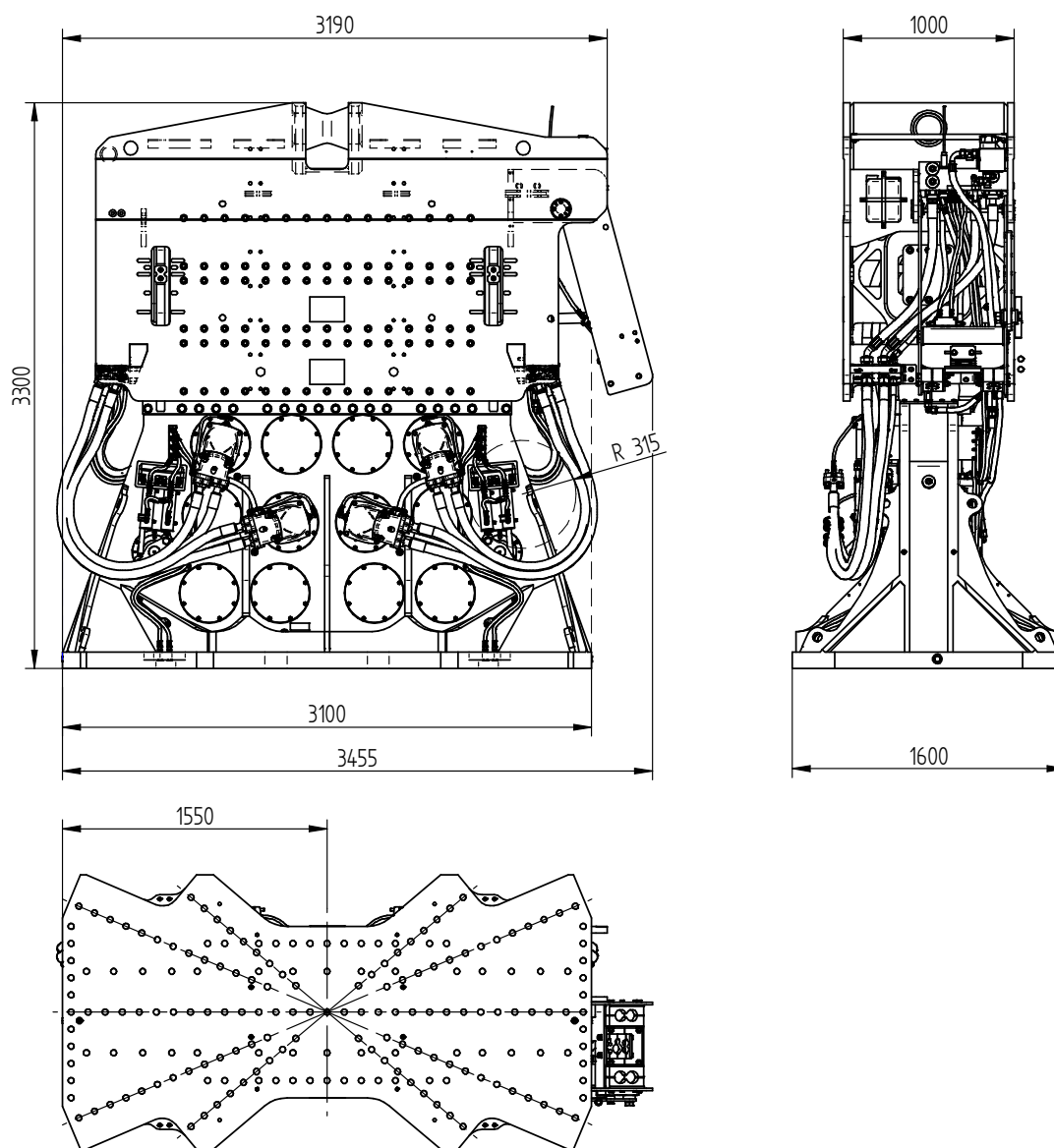

Spécifications

PVE 90VM

Moment excentrique	90 kgm	Pinces:	
Max. force centrifuge	4477 kN	Pince palplanche	PPK 150T
Max. fréquence	2130 rpm	Poids de transport par pièce	1600 kg
Max. amplitude sans 4xPPK 150T	13.3 mm	Pince tube	PPK 350T
Max. amplitude avec 4xPPK 150T	9.1 mm	Poids de transport par pièce	3600 kg
Force de traction statique	1500 kN		
Pression de travail max.	350 bar	Groupe hydraulique:	
Débit d'huile max.	2062 l/min	Modèle	1000P (2x)
Huile lubrifiante	oui		
Poids dynamique sans 4xPPK 150T	13500 kg	Jeu de tuyau:	
Poids dynamique avec 4xPPK 150T	19900 kg	Longueur	60 m
Poids total sans 4xPPK 150T & tuyaux	18500 kg	Poids de transport (±)	2630 kg



Specificaties

PVE 90VM

Vibro Hammer

Nederlands

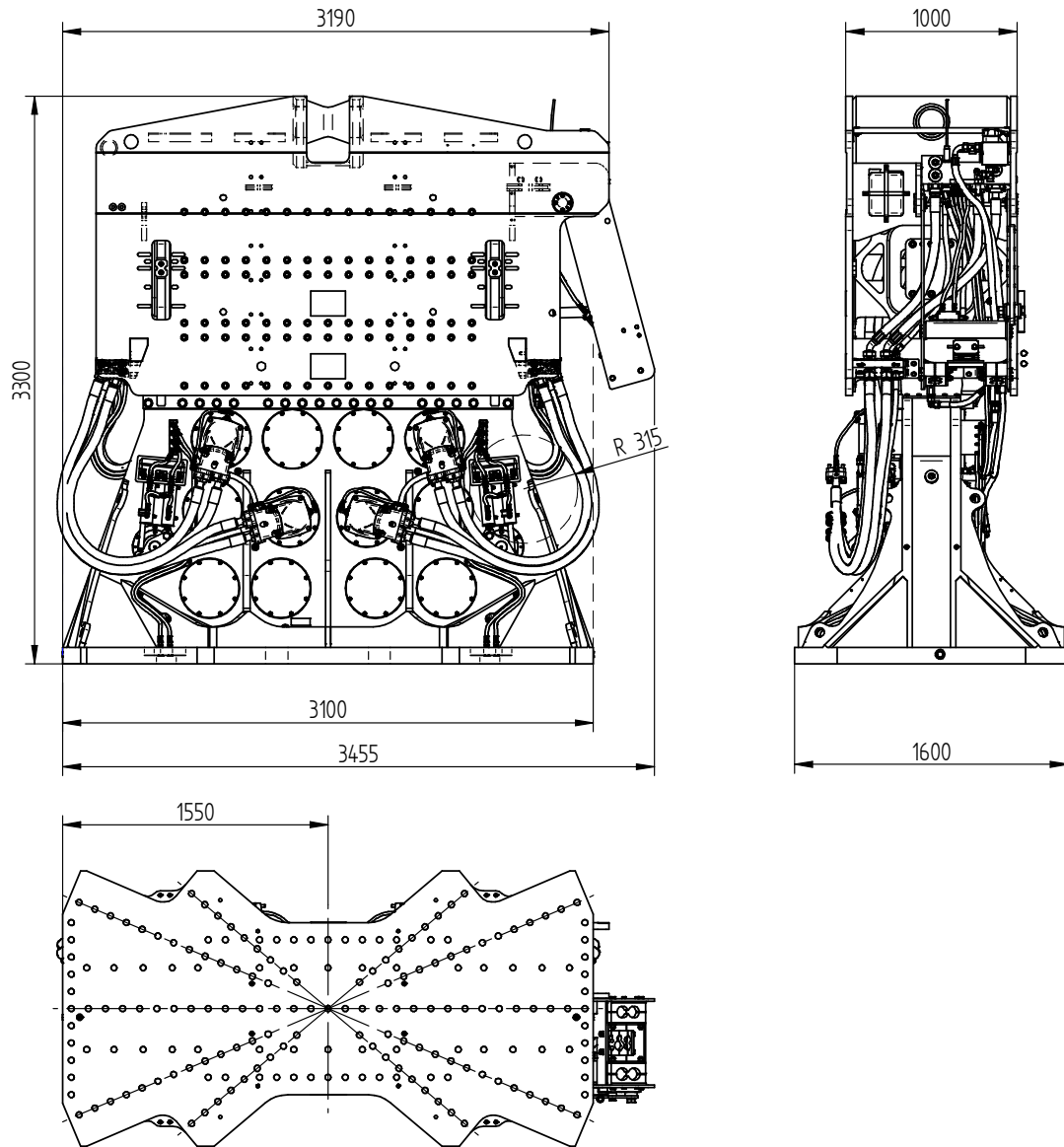

Specificaties

PVE 90VM

Excentrisch moment	90 kgm	Klemmen:	
Max. centrifugaalkracht	4477 kN	Damwandklem	PPK 150T
Max. toerental	2130 rpm	Transportgewicht per klem	1600 kg
Max. amplitude excl. 4xPPK 150T	13.3 mm	Pijpenklem	PPK 350T
Max. amplitude incl. 4xPPK 150T	9.1 mm	Transportgewicht per klem	3600 kg
Max. statische trekkracht	1500 kN		
Max. werkdruk	350 bar	Aggregaat:	
Max. oliedoorstroming	2062 l/min	Model	1000P (2x)
Geforceerde smering	ja		
Dynamisch gewicht excl. 4xPPK 150T	13500 kg	Slangenset:	
Dynamisch gewicht incl. 4xPPK 150T	19900 kg	Lengte	60 m
Totaalgewicht excl. 4xPPK 150T & slangen	18500 kg	Transportgewicht (±)	2630 kg



Especificaciones

PVE 90VM

Vibro Hammer

Español

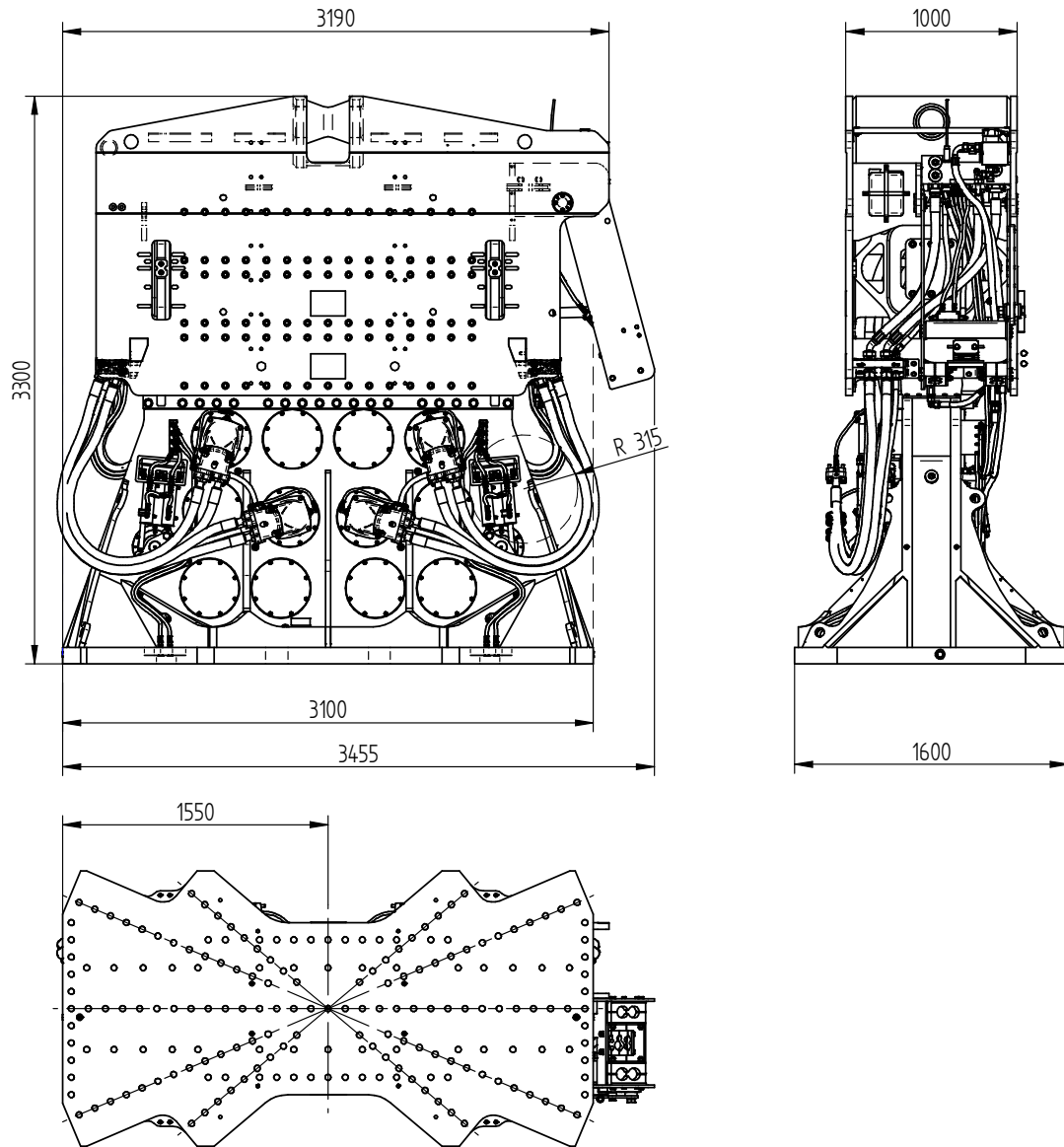

Especificaciones

PVE 90VM

Momento excéntrico	90 kgm	Abrazadera:	
Fuerza centrífuga máxima	4477 kN	Hoja abrazadera pila	PPK 150T
Frecuencia máxima	2130 rpm	Peso de transporte por pieza	1600 kg
Amplitud máxima excluyendo 4xPPK 150T	13.3 mm	Abrazadera de tubo	PPK 350T
Amplitud máxima incluyendo 4xPPK 150T	9.1 mm	Peso de transporte por pieza	3600 kg
Estático tracción máxima	1500 kN		
Presión máxima de trabajo	350 bar	Unidad de potencia:	
Flujo de aceite máximo	2062 l/min	Modelo	1000P (2x)
Lubricación forzada	si		
Peso dinámico excluyendo 4xPPK 150T	13500 kg	Conjunto de manguera:	
Peso dinámico incluyendo 4xPPK 150T	19900 kg	Longitud	60 m
Peso total excluyendo 4xPPK 150T & mangueras	18500 kg	Peso de transporte (±)	2630 kg



Specifications

PVE 90VM

Vibro Hammer

USA

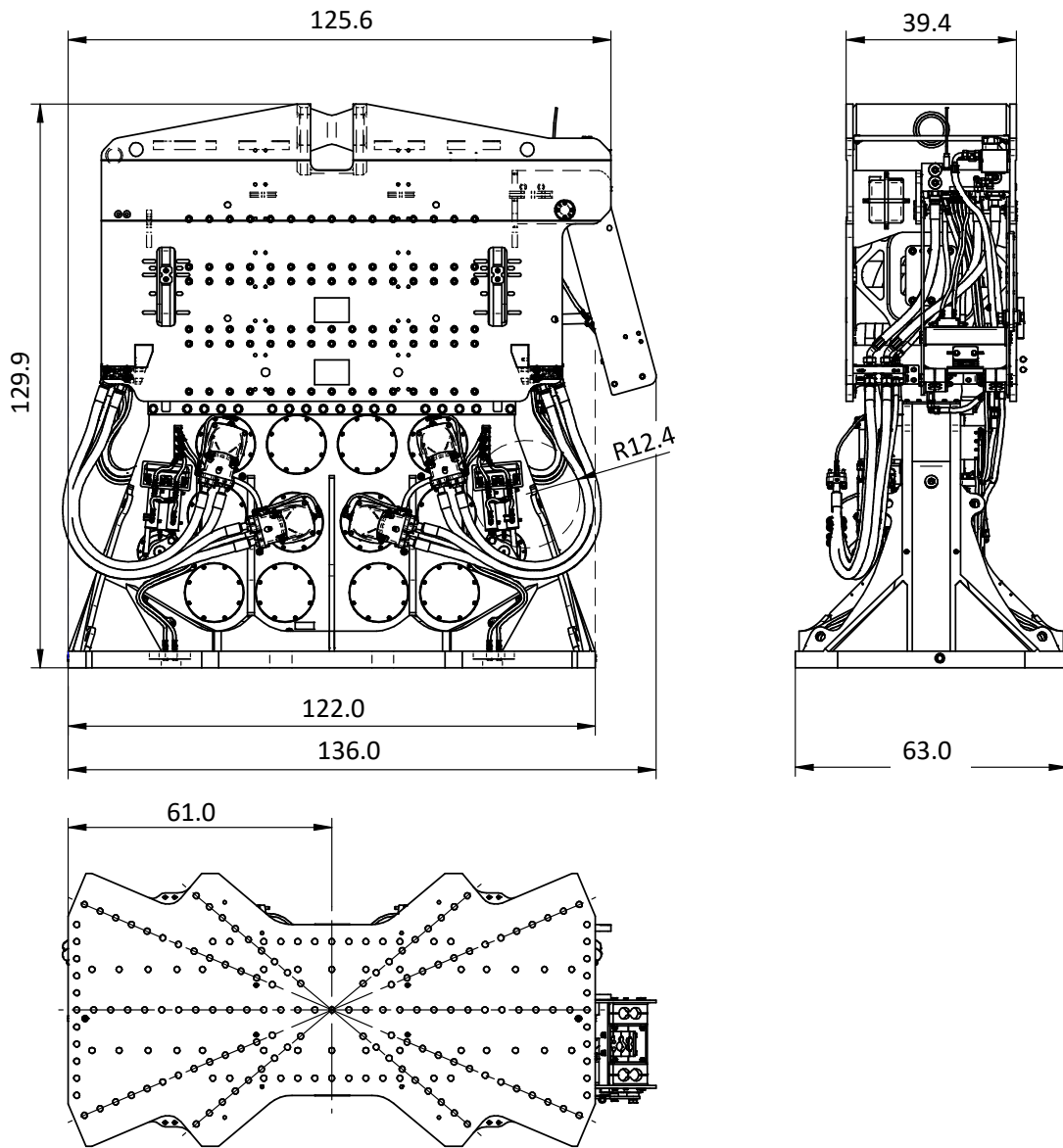

Specifications

PVE 90VM

Eccentric moment	0-7812.5 lbs in	Clamps:	
Max. centrifugal force	0-503.3 US tn	Sheet pile clamp	PPK 150T
Max. frequency	2130 rpm	Transport weight per piece	3527 lbs
Max. amplitude excluding 4xPPK 150T	0.52 in	Double clamps	PPK 350T
Max. amplitude including 4xPPK 150T	0.36 in	Transport weight per piece	7937 lbs
Max. static line-pull	153.0 US tn		
Max. operating pressure	5076 psi	Powerpack:	
Max. oil flow	545 gal/min	Model	1000P (2x)
Forced lubrication	yes		
Dynamic weight excluding 4xPPK 150T	29762 lbs	Hose set:	
Dynamic weight including 4xPPK 150T	43872 lbs	Length	197 ft
Total weight excluding 4xPPK 150T & hoses	40786 lbs	Transport weight (±)	5798 lbs